

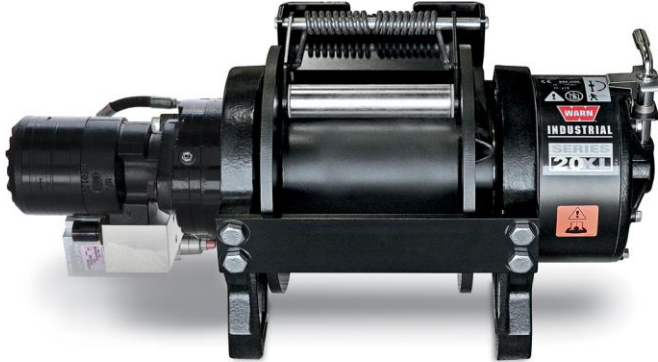

WARN Industrial Winch

Model	Part Number	Motor Type
Series 20XL-LP Hydraulic Winch Manual Clutch	78980	Hydraulic 11.9 ci (195cc)



The Warn Series XL product line combines durable cast iron construction, high efficiency hydraulic motor, and a robust 2X rated load braking system with a permanently lubricated and hardened 2-stage planetary gear train for superior intermittent-duty performance for loads up to 30,000 lbs. Winches are also available with manual or air clutches and 2 drum widths. A roller tension plate is standard along with bi-directional operation and a variety of mounting options to fit a variety of applications.

Warn Series XL winches are not suitable for hoisting applications or movement of persons.

Accessories

Description:	Part Number
Fairlead SRS-XL-STD	77532
Wire Rope Assembly 9/16"x140' EIPS	77451
Snatch Block XL-60K LB	80858

Engineering Data			
Rated Pulling Force:	20000	lbf	9072 kgf
Drum Barrel Diameter:	5.75	in	146 mm
Drum Flange Diameter:	12.25	in	311 mm
Distance Between Flanges:	8	in	203 mm
Recommended Maximum Wire Rope Diameter:	9/16	in	14.3 mm
Recommended Minimum Wire Rope Breaking Strength:	33600	lbf	15241 kgf
Approximate Shipping Weight:	297	lb	135 kg
Duty Cycle (intermittent per SAE J706 section 6.2):	2760	ft	841.2 m
Mounting Bolt Torque:	159	ft*lb	216 N*m
Maximum Layers of Wire Rope:	5		
Gear Reduction:	28.5:1		
Brake Type:	Spring Applied Disk		
Contact / Remote Type:	N/A		

Drum Rotation

Viewed from Motor End

Standards Compliance

- SAE J706
- CE Machinery Directive 98/37/EC and 2006/42/EC

Drum Layer	Line Load *			Line Speed 15 GPM		Line Speed 20 GPM		Drum Capacity	
	lbf	kgf	kN	ft/min	m/min	ft/min	m/min	ft	m
1	20000	9072	89.0	16.4	5.0	21.6	6.6	21	6.4
2	16975	7700	75.5	19.2	5.9	25.5	7.8	46	14.0
3	14745	6688	65.6	22.1	6.7	29.4	9.0	74	22.6
4	13032	5911	58.0	25.0	7.6	33.2	10.1	106	32.3
5	11676	5296	51.9	28.0	8.5	37.1	11.3	142	43.3

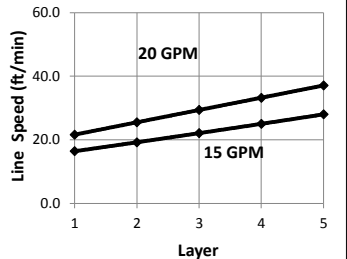

* Never exceed the Rated Pulling Force. Installation of a Rated Capacity Limiter is recommended.

First Layer Performance						
Line Load		Pressure Drop at 15 GPM		Pressure Drop at 20 GPM		Duty Cycle
lbf	kgf	psi	BAR	psi	BAR	min/10min
0	0	865	59.6	1020	70.3	N/A
5000	2268	1050	72.4	1315	90.7	N/A
10000	4536	1490	102.7	1650	113.8	N/A
15000	6804	1880	129.6	2050	141.3	N/A
20000	9072	2280	157.2	2460	169.6	N/A

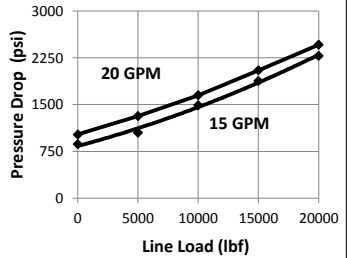

WARN INDUSTRIES, INC
Industrial Products

Customer Service (North America): 1.800.543.9276
Customer Service (International): 1.503.722.3008
FAX: 1.503.722.3000 www.warn.com

12900 S.E. Capps Road,
Clackamas, OR USA 97015



WARN Industrial Winch

Model

Part Number

Motor Type

**Series 20XL-LP
Hydraulic Winch
Manual Clutch**





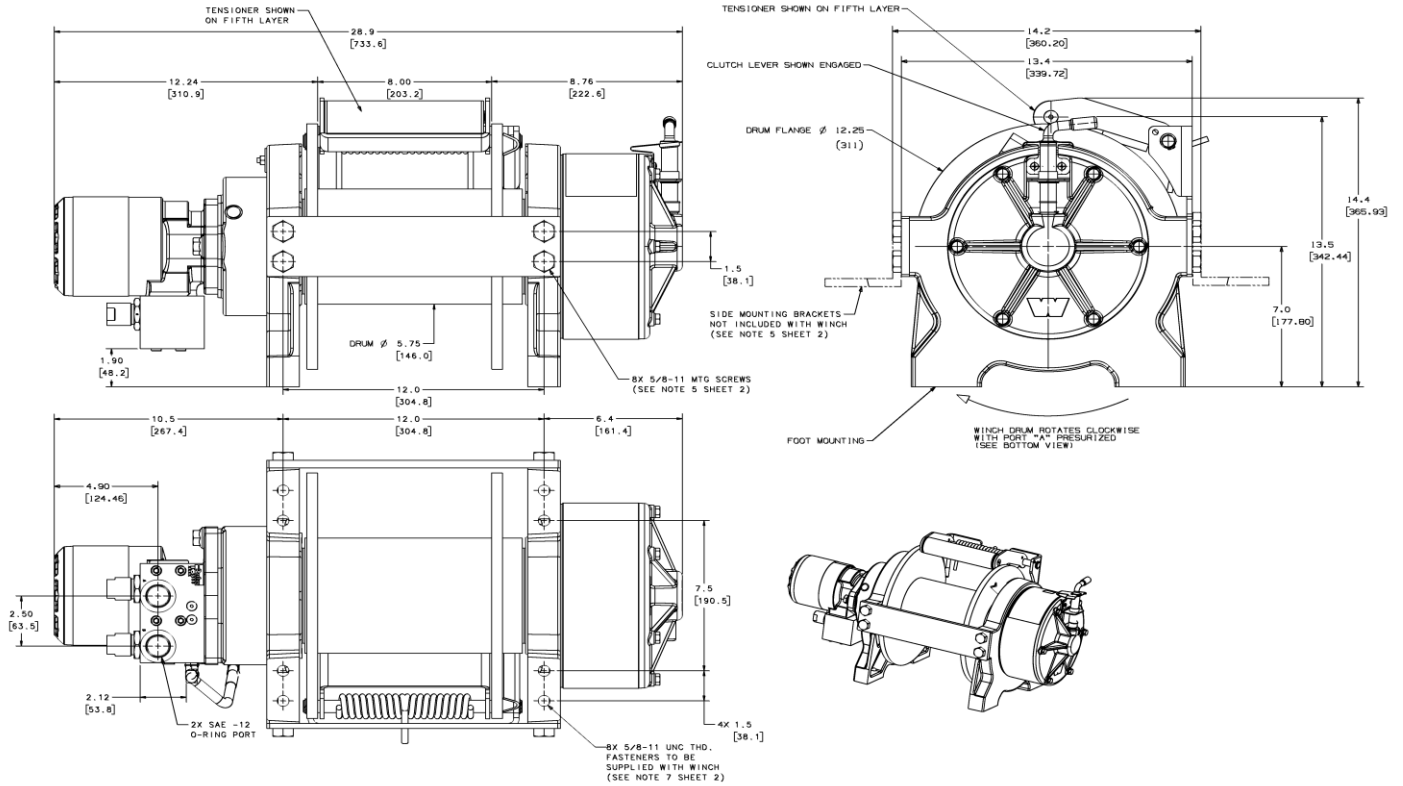



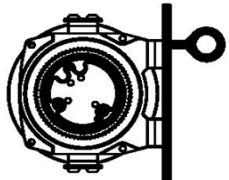
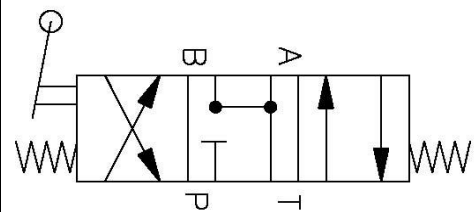

78980

Hydraulic
11.9 ci (195cc)



Motor / Contactor may be rotated in 90 degree increments. Clutch housing may be rotated in 60 degree increments.

Units are given in inches [millimeters], unless otherwise specified

Recommended Mounting- Always Observe Correct Drum Rotation			Hydraulic System Specifications		
Pull from bottom of winch 	Pull from bottom of winch 	Pull from top of winch 	Maximum System Pressure:	3000 psi	207 BAR
			Maximum Motor Pressure Drop:	3000 psi	207 BAR
			Maximum Rated Input Flow:	20 GPM	76 LPM
			Control Valve Type:	3-position, 4-way, open center, spring return (motor spool)	
Control Valve Schematic					
					
					
Note: Drum rotates clockwise with Port A pressurized when viewed from gearbox end.					
Feet down 	Feet forward 	Feet forward 			
Pull from top of winch 	Pull from top of winch 	Pull from top of winch 			
Feet down without angle brace	Feet down with angle brace	Angle Braces Only			

WARN INDUSTRIES, INC
Industrial Products

Customer Service (North America): 1.800.543.9276
Customer Service (International): 1.503.722.3008
FAX: 1.503.722.3000 www.warn.com

12900 S.E. Capps Road,
Clackamas, OR USA 97015