



WARN Industrial Hoist

Model

DC1000-Short Drum

Part Number

84350

Motor Type

DC Electric
12 Volt
Permanent
Magnet



The DC1000 hoist combines a powerful permanent magnet DC motor with robust sealing and our proven 3-stage all metal geartrain. Permanent grease lubrication means years of trouble free service. All WARN hoists incorporate an automatic mechanical brake that holds full rated load. The durable powder coated finish stands up to the elements and looks great. The DC1000 hoist is compact and comes standard with a steel mounting plate and hardware to make installation quick and easy. Controls and accessories available separately.

Accessories

Description:	Part Number
Roller Fairlead	28929
Control Pack-12V	63926
Contactors Only-12V	83321
Remote Control Only	88528

Engineering Data

Rated Capacity:	1000 lbf	454 kgf
Drum Barrel Diameter:	2.0 in	51 mm
Drum Flange Diameter:	4.1 in	104 mm
Distance Between Flanges:	3.0 in	76 mm
Recommended Maximum Wire Rope Diameter:	7/32 in	5.6 mm
Recommended Minimum Wire Rope Breaking Strength:	5600 lbf	2540 kgf
Approximate Shipping Weight:	18.0 lb	8.2 kg
Duty Cycle (intermittent per SAE J706 section 6.2):	N/A ft	N/A m
Mounting Bolt Torque:	11 - 13 ft*lbf	15 - 18 N*m
Maximum Layers of Wire Rope:	4	
Gear Reduction:	136:1	
Brake Type:	Disc	
Contactors/Remote Type:	Not Included	

Drum Rotation



Viewed from Motor End

Standards Compliance

1. - CE Machinery Directive 98/37/EC and 2006/42/EC
2. - CE Electromagnetic Compatibility 2004/108/EC

Performance By Layer

Drum Layer	Line Load *			No Load Line Speed		Drum Capacity	
	lbf	kgf	kN	ft/min	m/min	ft	m
1	1000	454	4.4	25.0	7.6	7	2.1
2	835	379	3.7	30.0	9.1	15	4.6
3	717	325	3.2	35.0	10.7	25	7.6
4	628	285	2.8	39.0	11.9	36	11.0

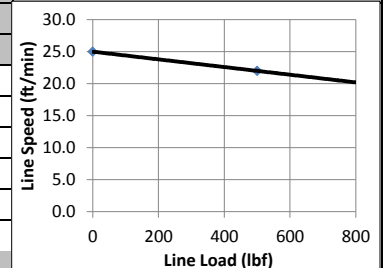

* Never exceed the Rated Capacity. Installation of a Rated Capacity Limiter is recommended.

First Layer Performance

Line Load		Current Draw	Line Speed		Duty Cycle
lbf	kgf	Amps	ft/min	m/min	min/10min
0	0	22	25.0	7.6	2.5
500	227	55	22.0	6.7	1.5
1000	454	87	19.0	5.8	0.8

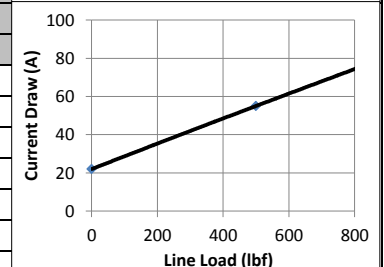

WARN INDUSTRIES, INC
Industrial Products

Customer Service (North America): 1.800.543.9276
Customer Service (International): 1.503.722.3008
FAX: 1.503.722.3000 www.warn.com

12900 S.E. Capps Road,
Clackamas, OR USA 97015



WARN Industrial Hoist

Model	Part Number	Motor Type
DC1000-Short Drum	84350	DC Electric 12 Volt Permanent Magnet

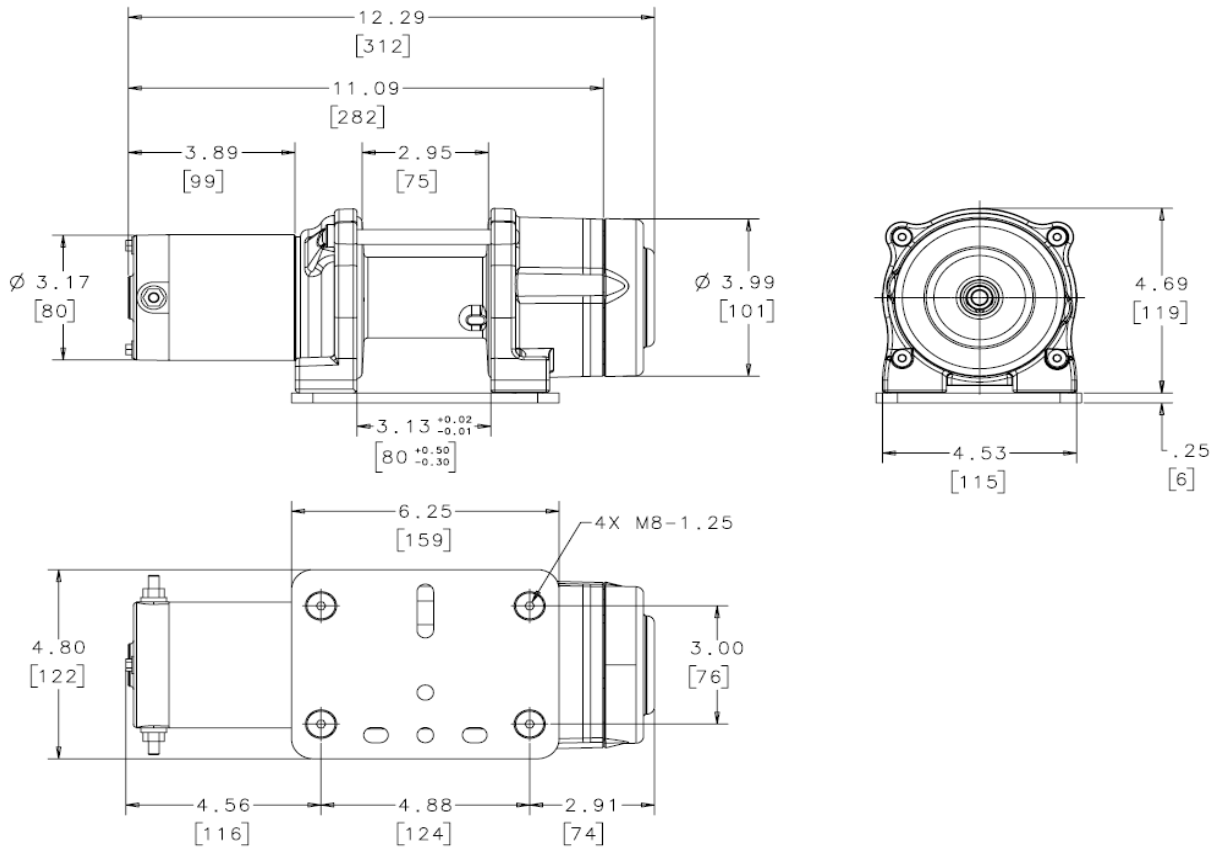

Units are given in inches [millimeters], unless otherwise specified

Recommended Mounting (Always Observe Correct Drum Rotation)

Electrical System Specifications

Pull from bottom of hoist

Pull from bottom of hoist

Pull from top of hoist

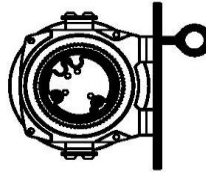

Feet down

Feet forward

Feet forward

Pull from top of hoist

Pull from top of hoist

Pull from top of hoist



Feet down without angle brace

Feet down with angle brace

Angle Braces Only

See Electrical Cable Gauge Size Chart for cable sizing

All electrical connections must be clean and tight

Electrical System Wiring Schematic

Hoist provided without electrical controls. See accessories on front page for control kits.

Power IN (Hoisting)- Connect Blue motor terminal to positive. Connect Yellow motor terminal to negative (Ground).

Power OUT (Lowering)- Connect Yellow motor terminal to positive. Connect Blue motor terminal to negative (Ground).

Notes:

WARN INDUSTRIES, INC
Industrial Products

Customer Service (North America): 1.800.543.9276
Customer Service (International): 1.503.722.3008
FAX: 1.503.722.3000 www.warn.com

12900 S.E. Capps Road,
Clackamas, OR USA 97015