



SERIES G2 PRODUCT DATA SHEET

MODEL	PART NUMBER	MOTOR TYPE
SG2 12-A-4.0H-10DL-WR00-MC	105440	Hydraulic 4.0 ci
SG2 12-C-4.0H-10DL-WR00-MC	105445	Hydraulic 4.0 ci
SERIAL NUMBER	INSPECTED BY	DATE

ENGINEERING DATA		
Rated Pulling Force:	12000 lbf	5443 kgf
Drum Barrel Diameter:	4 in	101.6 mm
Drum Flange Diameter:	8.24 in	209.3 mm
Drum Width:	9.95 in	252.7 mm
Evaluated Rope Diameter:	7/16 in	11 mm
Maximum Wire Rope Diameter:	1/2 in	12.7 mm
Minimum Wire Rope Breaking Strength:	20400 lbf	9253 kgf
Maximum Layers of Wire Rope:	4 with 7/16in rope	
Gear Train:	Planetary	
Gear Reduction:	36:1	
Mounting Bolt Size:	M12 X 1.75 Class 8.8	
Mounting Bolt Torque:	46-51 lbf-ft	63-69 Nm
Duty Cycle (per SAE J706 section 6.2):	266 ft	81.1 m
Approximate Shipping Weight:	85.3 lbf	38.7 kg
Brake Type:	Automatic Disk Brake per SAE J706 Sec. 4.2	
Sealing:	IP68/IP69K	
UV Rating:	1200 kJ/m ² per ASTM G154	
Corrosion Resistance:	408 hrs per ASTM B117	
Operating Temperature:	-40°F to 158°F (-40°C to 70°C)	
Decibels:	85.5 dB	
EMC Emissions:	N/A	
EMC Immunity:	N/A	



DESCRIPTION

SeriesG2 Hydraulic winches provide a more robust and serviceable design with a stronger gear train for increased performance. Less maintenance and less downtime means more work.

ACCESSORIES

SeriesG2 winches represents an all-new level of modular design, customization, and versatility, no matter the application. Please visit www.warn.com/industrial for all available accessories and options.

STANDARDS COMPLIANCE

2006/42/EC - EN ISO 12100:2010, EN 60529:1992+A2:2013, EN 14492-1:2006*
 2014/30/EU - EN 50498:2010, ISO 7637-2:2011, CISPR 25
 2011/65/EU - EN 63000:2018

Also complies with:
 SAE J706

*Conforms with exceptions

PERFORMANCE BY LAYER

DRUM LAYER	LINE LOAD*			LINE SPEED 10 GPM		LINE SPEED 15 GPM	
	lbf	kgf	kN	ft/min	m/min	ft/min	m/min
1	12000	5443	53.4	19	5.9	31	9.3
2	10024	4547	44.6	24	7.2	37	11.2
3	8606	3904	38.3	27	8.3	43	13.0
4	7540	3420	33.5	31	9.4	49	14.8

*Never exceed the Rated Pulling Force. Installation of a Rated Capacity Limiter is recommended

DRUM ROTATION

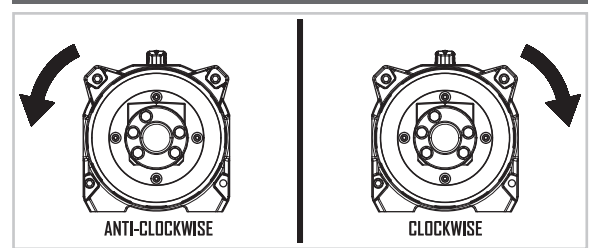

As viewed from motor end

FIRST LAYER PERFORMANCE

LINE LOAD		PRESSURE DROP AT 10 GPM		PRESSURE DROP AT 15 GPM		DUTY CYCLE
lbf	kgf	psi	BAR	psi	BAR	min/10min
0	0	214	14.8	441	304.4	N/A
2000	907	578	39.9	732	50.5	N/A
4000	1814	942	64.9	1052	72.6	N/A
6000	2722	1306	90.0	1392	96.0	N/A
8000	3629	1669	115.1	1754	120.9	N/A
10000	4536	2033	140.2	2125	146.5	N/A
12000	5443	2397	165.3	2526	174.1	N/A

FIRST LAYER PERFORMANCE

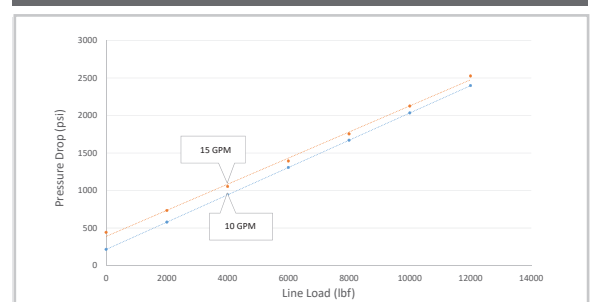



SERIES G2 PRODUCT DATA SHEET

MODEL	PART NUMBER	MOTOR TYPE
-------	-------------	------------

SG2 12-A-4.0H-10DL-WR00-MC	105440	Hydraulic 4.0 ci
SG2 12-C-4.0H-10DL-WR00-MC	105445	Hydraulic 4.0 ci

DRUM LAYER CAPACITY PER EVALUATED ROPE DIAMETER

DRUM LAYER	DRUM LENGTH							
	6.5"		8"		10"		12.5"	
	ft	m	ft	m	ft	m	ft	m
1	15	4.6	19	5.8	24	7.3	29	8.8
2	32	9.8	42	12.8	53	16.2	63	19.2
3	52	15.8	69	21.0	86	26.2	104	31.7
4	75	22.9	100	30.5	125	38.1	150	45.7

TOTAL DRUM CAPACITY

ROPE DIAMETER	DRUM LENGTH							
	6.5"		8"		10"		12.5"	
	ft	m	ft	m	ft	m	ft	m
7/16	75	22.9	100	30.5	100	30.5	150	45.7
1/2	60	18.3	60	18.3	75	22.9	100	30.5

HYDRAULIC SYSTEM SPECIFICATIONS

Maximum System Pressure:	2500 psi	172 BAR
Maximum Motor Pressure Drop:	2398 psi	165.3 BAR
Maximum Rated Input Flow:	15 GPM	57 LPM
Maximum Rated Input Speed:	946	RPM
Control Valve Type:	Tandem Center	

CONTROL VALVE SCHEMATIC

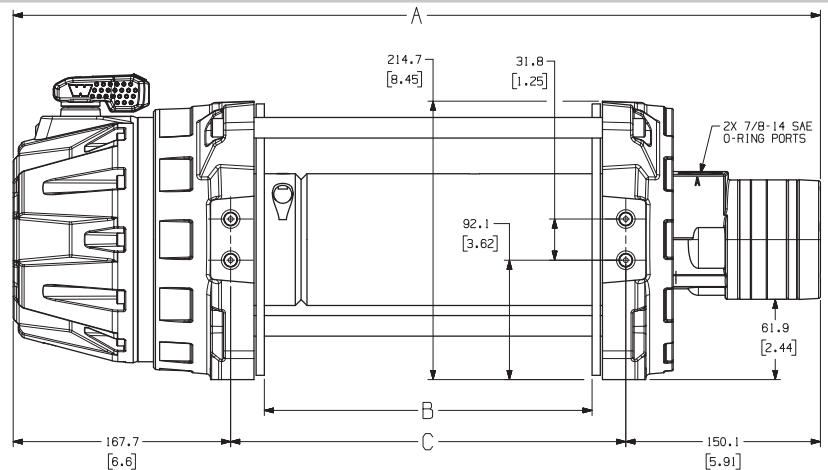
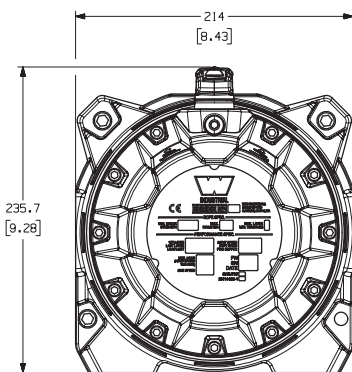
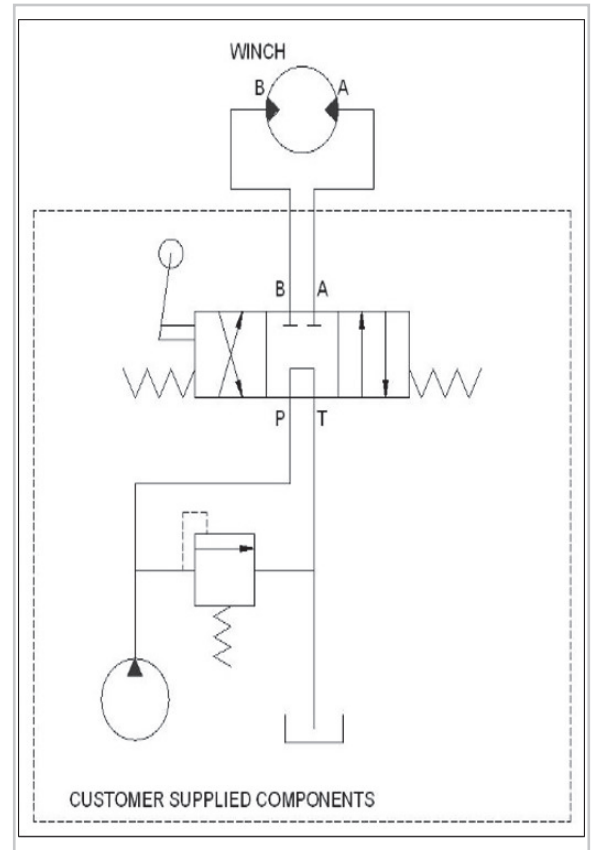

DRUM SIZE	UNITS	A	B	C
6.5" DRUM	mm	533.6	163.8	215.8
	in	21.01	6.45	8.50
8" DRUM	mm	571.7	201.9	253.9
	in	22.51	7.95	10.00
10" DRUM	mm	622.5	252.7	304.7
	in	24.51	9.95	12.00
12.5" DRUM	mm	686.0	316.2	368.2
	in	27.01	12.45	14.50

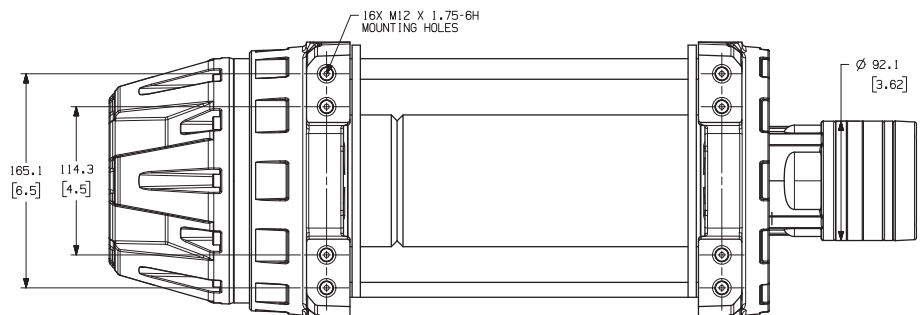

WARN INDUSTRIES, INC
INDUSTRIAL PRODUCTS

Customer Service (North America): 1.800.543.9276
Customer Service (International): 1.503.722.3008
www.warn.com

12900 S.E. Capps Road,
Clackamas, OR USA 97015



MOUNTING CONFIGURATIONS

MODEL	PART NUMBER	MOTOR TYPE
SG2 12-A-4.0H-10DL-WR00-MC	105440	Hydraulic 4.0 ci
SG2 12-C-4.0H-10DL-WR00-MC	105445	Hydraulic 4.0 ci

ALL MOUNTING MUST BE OBSERVED FROM MOTOR END

FEET DOWN, ROPE UNDER DRUM, COMING IN FROM THE LEFT (DUL) - ANTI-CLOCKWISE ROTATION

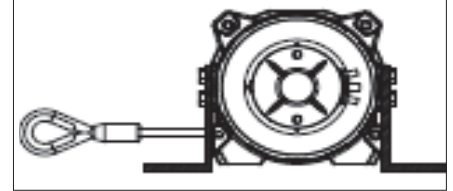
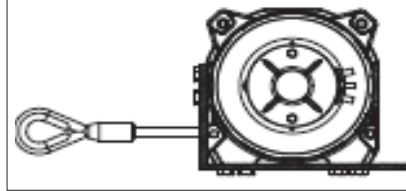
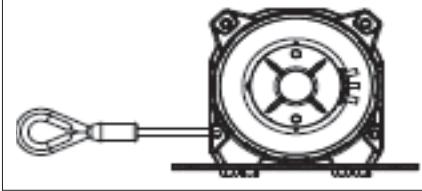

FEET DOWN, ROPE UNDER DRUM, COMING IN FROM THE RIGHT (DUR) - CLOCKWISE ROTATION

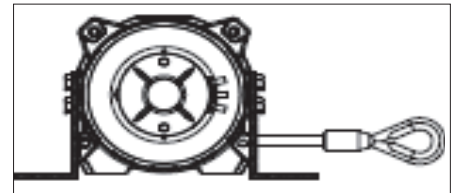
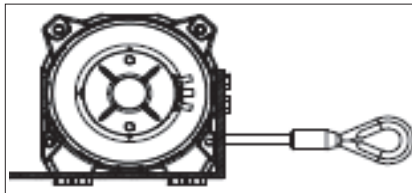
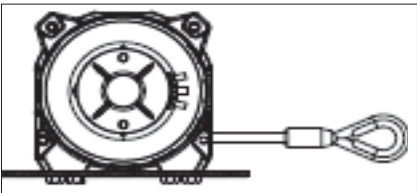

FEET DOWN, ROPE OVER DRUM, COMING IN FROM THE LEFT (DOL) - CLOCKWISE ROTATION

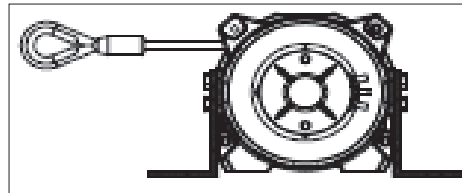
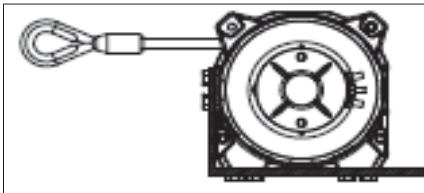

FEET DOWN, ROPE OVER DRUM, COMING IN FROM THE RIGHT (DDR) - ANTI-CLOCKWISE ROTATION

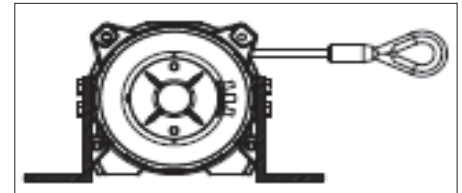
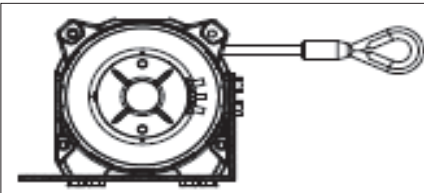

FEET FORWARD, ROPE OVER DRUM, COMING IN FROM THE LEFT (FOL) - CLOCKWISE

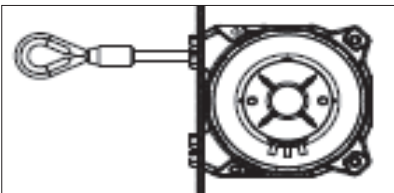

FEET FORWARD, ROPE UNDER DRUM, COMING IN FROM THE LEFT (FUL) - ANTI-CLOCKWISE

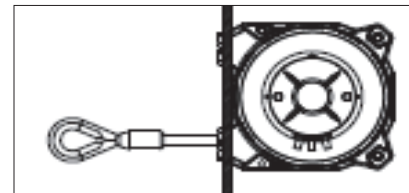

FEET FORWARD, ROPE OVER DRUM, COMING IN FROM THE RIGHT (FOR) - ANTI-CLOCKWISE

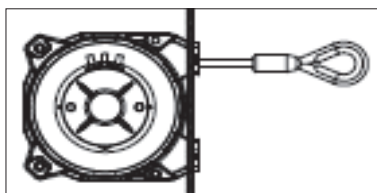

FEET FORWARD, ROPE UNDER DRUM, COMING IN FROM THE RIGHT (FUR) - ANTI-CLOCKWISE

